

### Kenbri Foam Nozzles

Foam nozzles are air-aspirating foam-water discharge devices. Installed in foam-water sprinkler systems, they help protect flammable liquid risks.

Low expansion foam nozzles are available pendent or upright. The medium expansion nozzle is a pendent basket-type nozzle.

### Construction features

Material UAS-UP/PD: Bronze  
 Material UAS/INOX(S.S): Stainless steel

### Optional

Different connections (ANSI/ASA)  
 Other flow rates available

### Technical Data

Model	Type	K Factor	Expansion	Material	Weight (kg)
UAS-UP	Upright	41.2	1:6	Bronze	0.5
UAS-PD	Pendent	41.2	1:6	Bronze	0.5
UAS/INOX(S.S)	Pendent	41.2	1:6	Stainless Steel	0.5

\* Depending on foam concentrate type

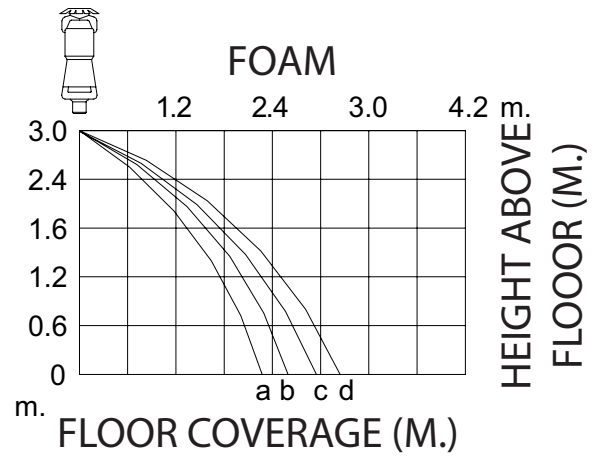
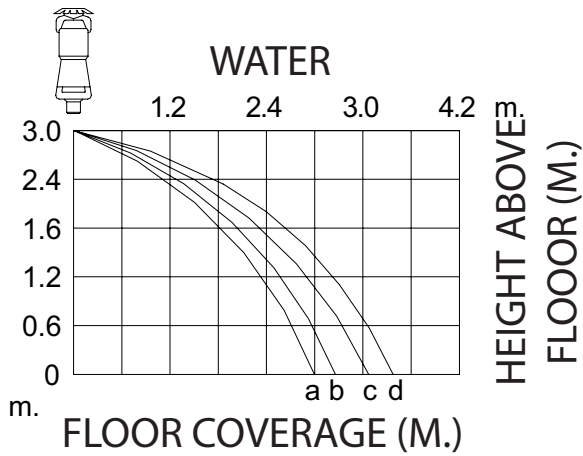

a = 2 bar  
 b = 3 bar  
 c = 4.5 bar  
 d = 6 bar

